

Program "ASOP" (Optical Systems Analysis)

Enrique J. Campitelli.

Mariano G. Berisso. (subroutines "EligeArchivo" and "Errores").

The compiled version of this program can not be accessed from an hyperlink as the others because it request an auxiliary data structure. It must be downloaded from the Web in a particular machine, unzipping the file "asop.exe" available in the contents page <http://www.ecampitelli.com.ar/Ingles/contenido.htm>

It must be created a new folder called "asop". On executing "unzipasop.exe", it will be requested a place where unzip it, showing "unzip to folder", and a space where the folder can be selected. Select the folder "asop", key "unzip" and the program "asop.exe" will be ready in that folder.

It uses what was shown in chapter 4 – Geometrical Optics – to plot a polychromatic spot diagram in such places where the rms dispersion of the rays is least, in each of three defined colors. There are traced 1300 rays in each color over a system of up to 50 surfaces.

The segments at the bottom of the diagram are the diameters of the Airy disks.

Also there are shown statistical and paraxial parameters related to the image, data about the optical system, about the glasses, and a drawing of the system.

It only deals with coaxial systems with aspherics up to 8th order. The program request two files: One of glasses and other of systems, and is easy to operate. It makes intensive use of color as indicator parameter, and emphasis has been put on the simplicity of inputs and clarity of outputs.

On start there appear three options

Optical **s**ystem
Glass
File

With **s** it is defined a new system, *and it must be placed in front of the name a number indicating how many surfaces it has*. With **G** it is defined a new glass, *and no number must be placed in front of the name*.

With **F** it is read from the corresponding file a system or a glass, and the program will furnish one or another, depending on how its name begins. To understand its operation is better to start the program reading one of the included files and follow the options, generally highlighted in red.

As the options are replaceables, this says how to introduce new elements. All is explained in the screen.

In the glass file there are all from the Schott catalog, plus some specials.

In the systems file there are all the examples given in the text, plus some specials.

Typing several times "enter" it may be finished from any point.

The program gives correct results and is well documented and commented, but the programming technique is still crude.

Given that is somewhat long to print the source code – and by now it is not an example to programmers – it was decided to not publish it, but is available in e_campitelli@hotmail.com y campitelli.enrique@gmail.com, and is in process of improving its codification. In his place goes a flow diagram. The points of decision in the red polygons are indicated in the upper left corner of the screen.

Optical systems included in the file

1	1-parabo	Simple parabolic mirror
2	11-ild80	Photographic objective of Double Gauss type
3	2-burek	Cassegrain telescope of Casleo
4	2-lupach	Simple loupe for experiments
5	2-rcleo	Ritchey-Chretien telescope of Casleo
6	3-aplacr	Achromatic aplanatic doublet
7	3-aplcem	Cemented aplanatic doublet
8	3-appcem	Cemented aplanatic apochromatic doublet
9	3-mersch	Mersenne – Schmidt telescope
10	3-schmid	Schmidt camera
11	3-stand	Standard problem, single pass
12	4-acro	Achromatic doublet (a)
13	4-apoc	Apochromatic doublet (b)
14	4-bowers	Concentric Bowers camera
15	4-c14	Celestron 14 telescope
16	4-maksig	High performance Maksutov telescope
17	5-bowac	Achromatic concentric Bowers camera
18	5-stand	Standard problem, double pass
19	6-aplana	Sequence of three aplanatic lenses.
20	7-rowypa	Ross-Wynne corrector for 2-burek
21	8-argus	Schmidt camera for Argus. Casleo report of 18/04/02
22	8-copy	Lens for microfilm
23	8-heliar	High definition aerophotographic objective
24	9-relay	Relay lens for Reosc and Casprof

FLOW DIAGRAM OF ASOP

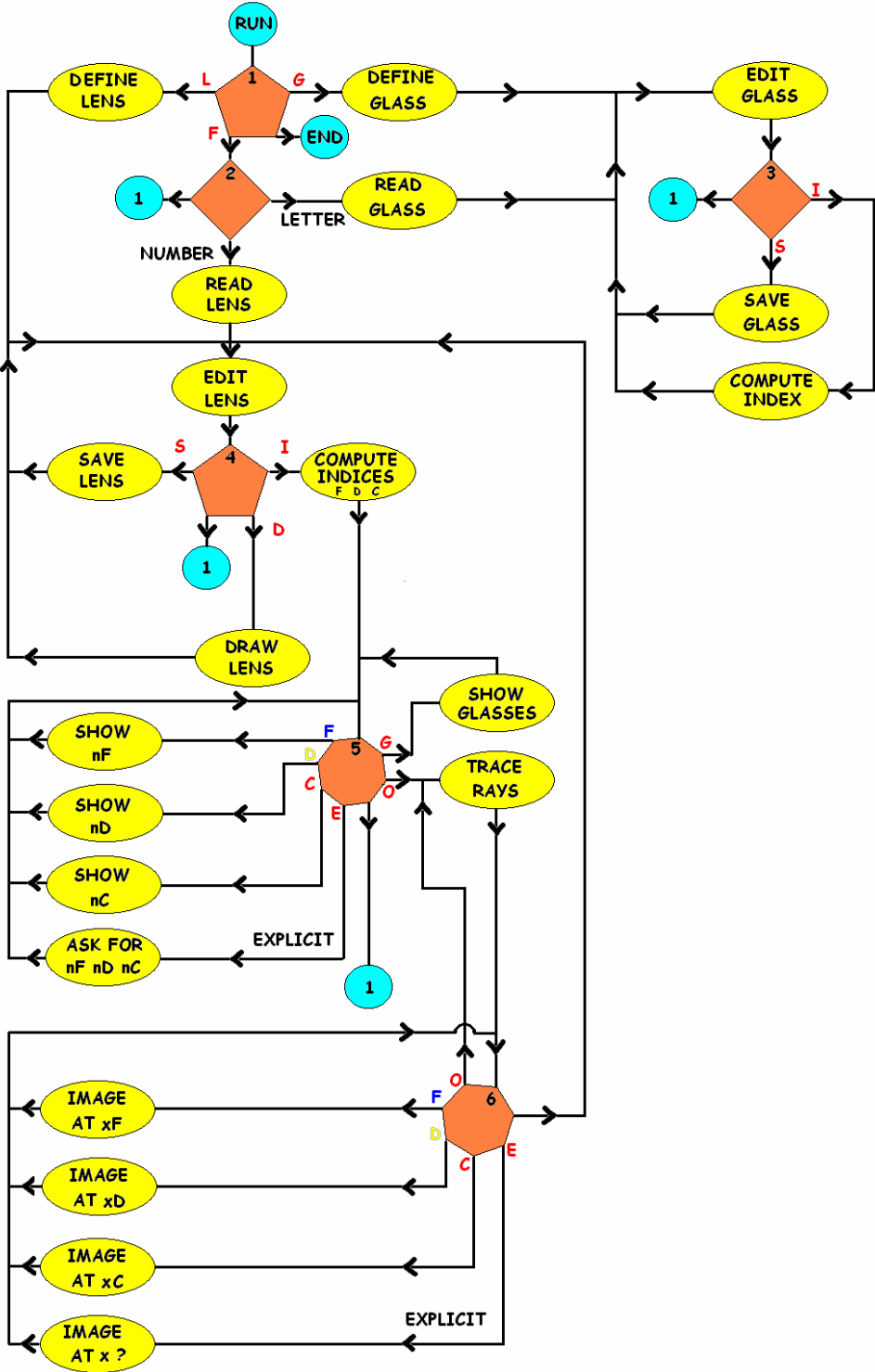

Exercises with ASOP

The purpose of this exercises is to understand optical concepts and validate the program ASOP. As it is a subject of general geometrical optics, there are dealt with varied optical systems, not just astronomical.

To better understanding the figures that follow we will see the first output screen as it appears in the monitor.

```

Object      Focus:      F      D      C      Explicit
-----
Object distance = 0 ?
Semifield in degrees = 12 ?

8-heliar

XEP = 63.48615      distance X from surface 1 to Entrance Pupil
REP = 52.75985      Radius of Entrance Pupil
XXP = -65.17502     distance X from surface 8 to eXit Pupil
RXP = 55.16748     Radius of eXit Pupil
XOPP = 89.94019     distance X from surface 1 to Object Principal Plane
XIPP = -37.51381    distance X from surface 8 to Image Principal Plane

Data in the graph:

x = position of actual focus
WLÅ = WaveLength in Å
PEF = Paraxial Effective Focal distance
PBF = Paraxial Back Focal distance
ABF = Average Back Focal distance
YPP = height Y of Principal Paraxial ray - printed as ->
      or a | in the frame to where escaped
YPG = height Y of Principal General ray - printed as ->
YA = Y Average of the image - printed as ->
TL = fractional Transmitted Light = 1-(vignetting + obstruction + Fresnel)
  
```

Fig 1. Screen previous to the graphic with paraxial data in central color (D) and explanations for the graphic. The current lens will be seen in an example below.

Evaluation of transmitted light.

The quantity TL printed in the spot diagram evaluates the fraction of transmitted light in each color, which is attenuated by three causes: Fresnel reflections at the refracting surfaces, central obstruction and vignetting. For the last two, an inventory is made of lost rays by falling out of borders, and for the first it is used the Fresnel formula under normal incidence. As in most lenses light incides near normal, this gives good enough results. The light reflected in a non metallic surface is:

$$(1) \quad R = \left(\frac{n_i - n_r}{n_i + n_r} \right)^2$$

Where i refers to incident medium and r to the refracted.

When there are several surfaces 1, 2, 3..., is $TL = (1 - R_1)(1 - R_2)(1 - R_3)...$

Losses by Fresnel reflection:

Let us take as example an apochromatic doublet. (From file: 4-apoc).

Using the option **I**mage, accepting the default wavelenghts and using then the options **F**, **D**, **C**, results the following sequences of indices:

Color	Surface 1	Surface 2	Surface 3	Surface 4
F	1.52499	1	1.66697	1
D	1.51899	1	1.65536	1
C	1.51653	1	1.65062	1

The explicit expression for TL is, for example, for color **D**:

$$(2) \quad TL = \left[1 - \left(\frac{1 - 1.51899}{1 + 1.51899} \right)^2 \right] \left[1 - \left(\frac{1.51899 - 1}{1.51899 + 1} \right)^2 \right] \left[1 - \left(\frac{1 - 1.65536}{1 + 1.65536} \right)^2 \right] \left[1 - \left(\frac{1.65536 - 1}{1.65536 + 1} \right)^2 \right]$$

$$= 0.8086$$

The fractions TL given by ASOP are, in the three colors:

Color	TL
F	0.8045
D	0.8086
C	0.8103

The fraction in short λ (**F**) is less because the indices are larger.

These values are obtained if the semifield angle is zero, for otherwise it may be vignetting losses.

Vignetting losses and central obstruction:

For this case we take the Sahade telescope of CAsLeo. (From file: 2-rcleo)

The obstruction is defined in the primary mirror. The clear radius is 1075 mm and the dark radius is 430 mm

Hence the fraction TL on axis is:

$$(3) \quad TL = 1 - \left(\frac{430}{1075} \right)^2 = 0.84$$

It depends on the ratio of areas, and we assume the mirrors reflecting all light. Although this is not true, their reflectivity depends on practical factors non calculable. With ASOP are obtained values randomly fluctuating in several runs of the program. This is due because the rays are traced starting with a random definition of their intersection at the entrance pupil, and the quantity of lost rays is not the same ever. This happens with all quantities statistically evaluated over the bundle of rays, say, also the position MBF of the mean back focus and mean height MY of the image. To obtain a more accurate value it is necessary to trace more rays or trace them several times without restart the program and make an average.

If the matrix of spots where regular, the data would be numerically exact but fictitious.

The random initial values are repeated when restarting the program, so that the obtained values also repeat.

If it is chosen an object height (semifield in degrees) = 0, the values of TL are:

0.8313, 0.8640, 0.8353, 0.8420, 0.8380, 0.8327, 0.8477. Average: 0.839

To appreciate the aspect of a central obstruction it is adequate to set as **E**xplicit focus $x = 0$; this plots the ray distribution at zero distance from the last surface, that is, on the secondary mirror.

As it is far enough from the image, the bundle is a truncated cone without deformation and only is seen the non blocked part. (Fig. 2). The extension of this "image" is indicated in the lower left corner and is 592 mm. As the secondary mirror has a clear radius 316 mm (diameter 632 mm), the beam still has a margin and no light is lost.

Taking the allowed semifield angle 0.25 degrees the situation does not change, but if it is taken an angle of 1 degree (much larger than allowed), the pupil shows an asymmetry. The symmetrical initial figure is displaced and disappears in part over a larger circular contour.

The interpretation of this is that the beam falls in part outside the border of the secondary, that is, there is vignetting. (Fig. 3).

This is seen more pronounced with an angle of 2 degrees (Fig. 4), and for 8 degrees no pass any light, that is, the beam falls outside the secondary. The values of TL keep track of what happens.

(For reasons of clarity and fidelity only the images where there is no dispersion as in the case of mirrors or monochromatic evaluation are shown in black with white background)

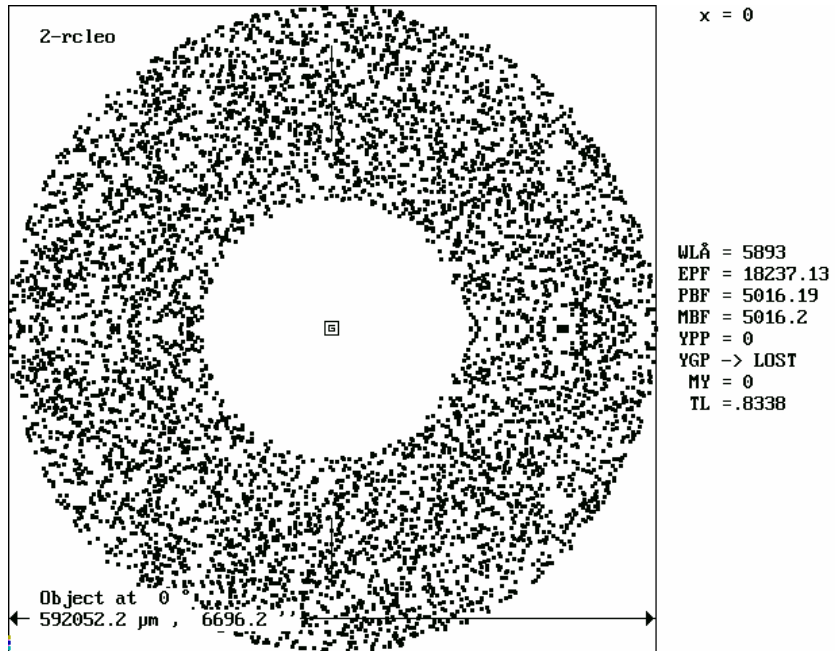

Fig. 2

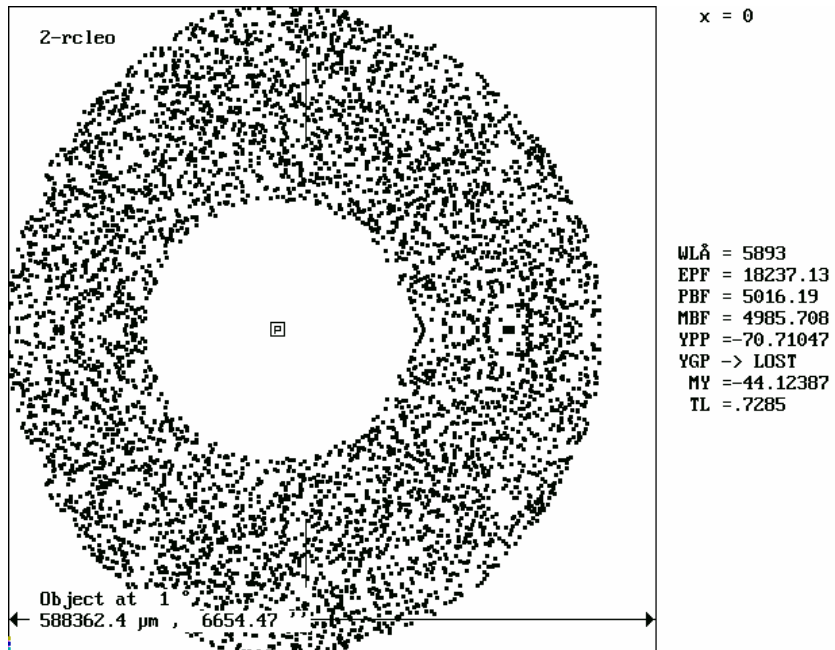

Fig. 3

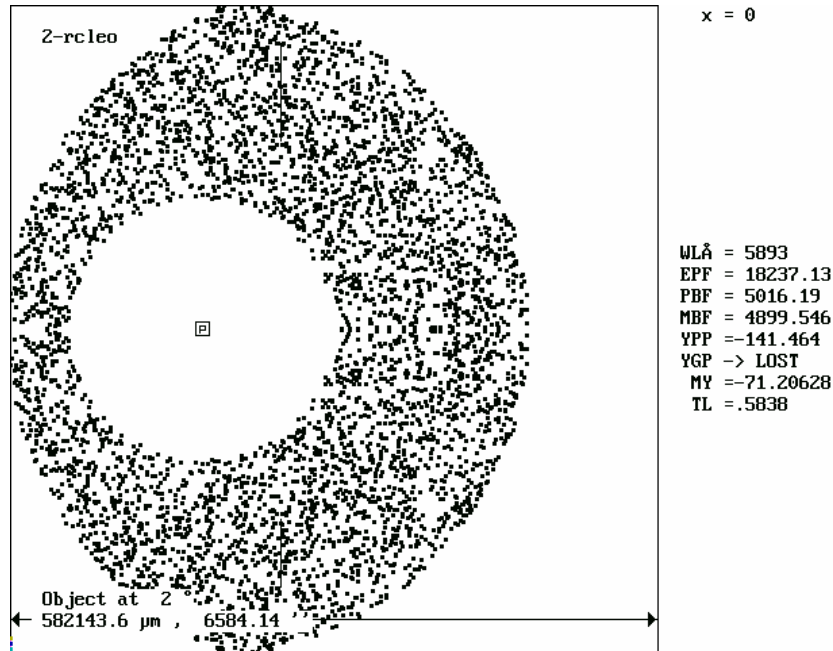

Fig 4

Curvature of field

This aberration does not affect the sharpness of the image, but the place where it is formed so that it cannot be appreciated in the spot diagram. To evaluate it there are needed the quantities at the right of the diagram.

Again we use the CASLeo telescope, where it is clearly seen. Changing the semifield angle from 0 to 0.25 degrees, the distance of the mean back focus *MBF* change from 5016.195 mm to 5014.219 mm, and the mean height *MY* of the image go from 0 to -79.557 mm (averaging 7 values).

Hence the image forms over a curved surface, a sphere approximated by a parabola if the aberration is of the third order, as is this case being small the field and aperture.

The difference in focal lengths is $\delta MBF = -1.975$ mm and the equation of the curve is

$$\delta MBF = MY^2 / 2 R, \text{ where } R \text{ is the radius of curvature of the focal surface.}$$

Then, $R = -1602.358$ mm. The negative sign indicates that the concavity points to where light is coming.

Diffraction limit

Continuing with the same telescope, we see that in the lower left corner of the graph there are three segments in colors blue, yellow and red. These are the diameters of the Airy diffraction disks, that are the aspect of the image if aberrations vanish.

The expression for the linear diameter of the Airy disk is:

$$d = 2.44 \lambda EPF / D$$

Where D is the diameter of the aperture stop, in this case the primary mirror.

Taking a mean value of λ , 5893 Å, (D line).

Results $d = 12 \mu\text{m}$, in agreement within the approximations of the case, with the length of the segment at the scale of the graph.

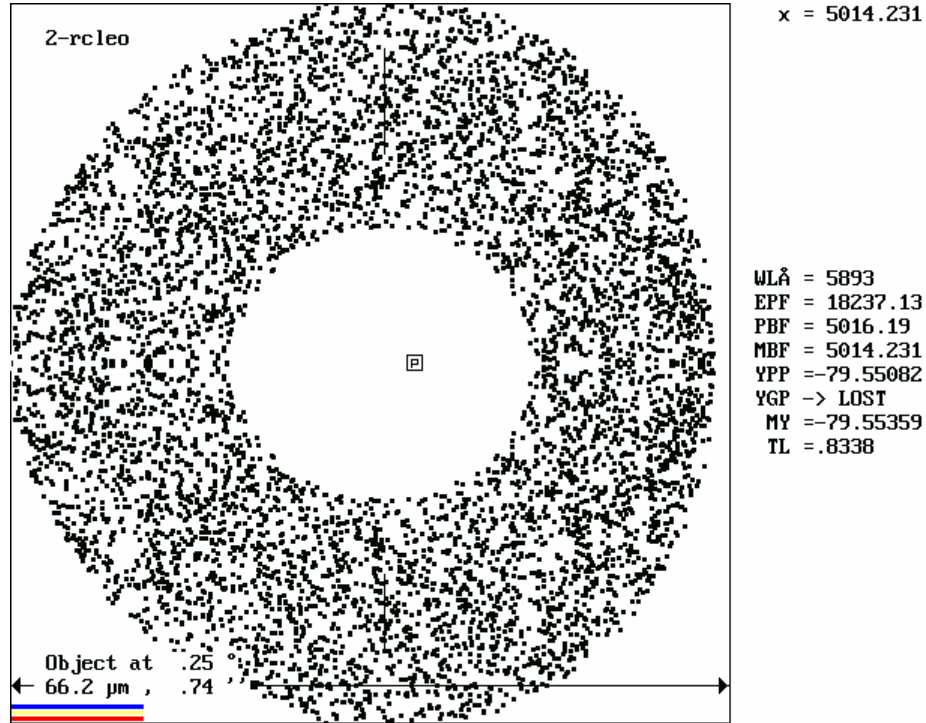

Fig 5. Image at the edge of field, middle between two elongated astigmatics.

Closing the diaphragm of a photographic objective.

The effect of closing the diaphragm is well known: it decreases the illumination of the image, increases depth of focus and improves somewhat definition.

Let us see the last effect.

The objective studied is the Heliar (Ref. 1, from file 8-heliar). The diaphragm is the surface 4. Initially the clear radius of the diaphragm is 44.3 mm, and reach the border of the lens. Fig. 6 is the image with the diaphragm wide open and in Fig. 7 it was closed to 38 mm.

The effect of this slight reduction is the elimination of the blue halo, but the nucleus remains the same. The amount of light is reduced by a factor 0.73, that is the ratio of areas, and the differences in *TL* are vignetting effects.

The loss of light in diaphragming is proportional to the ratio of areas. It does not shows in *TL* because the diaphragm is defined as the place where all rays pass. There are no lost rays in the diaphragm.

This lens has a very good imagery and has been pushed to the limit both in aperture and field. The degradation of the image with field is left as another exercise.

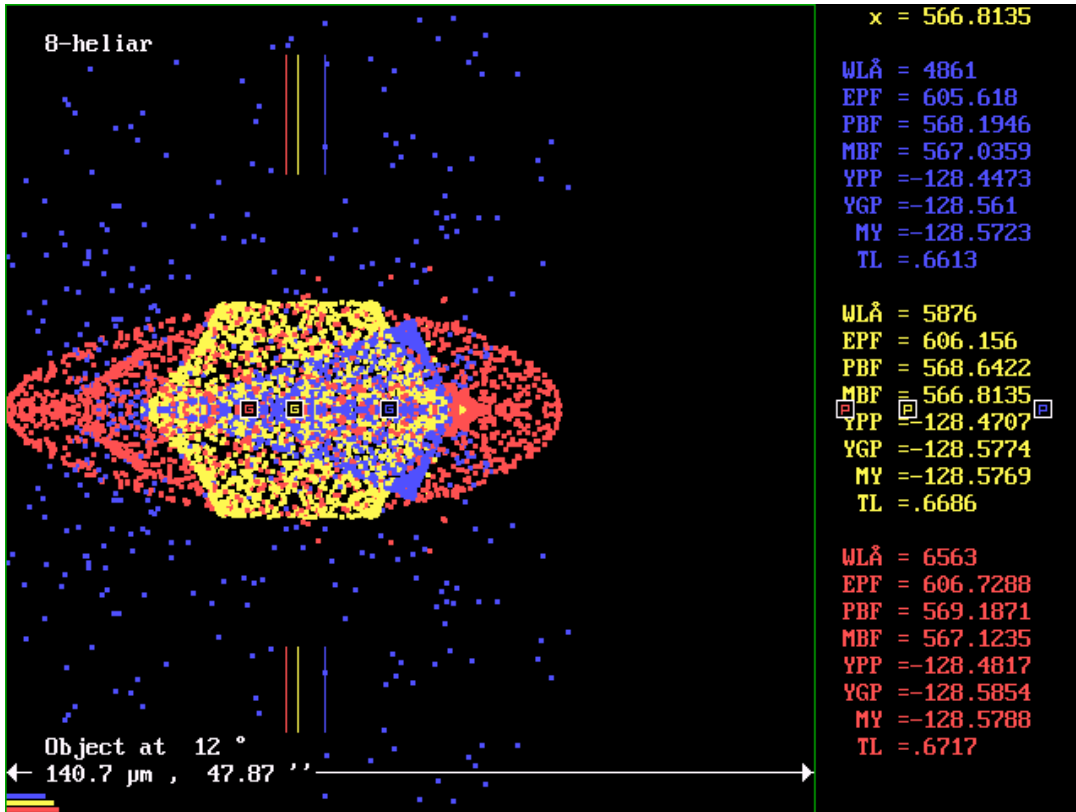

Fig 6. 8-heliar with diaphragm 44.3 mm

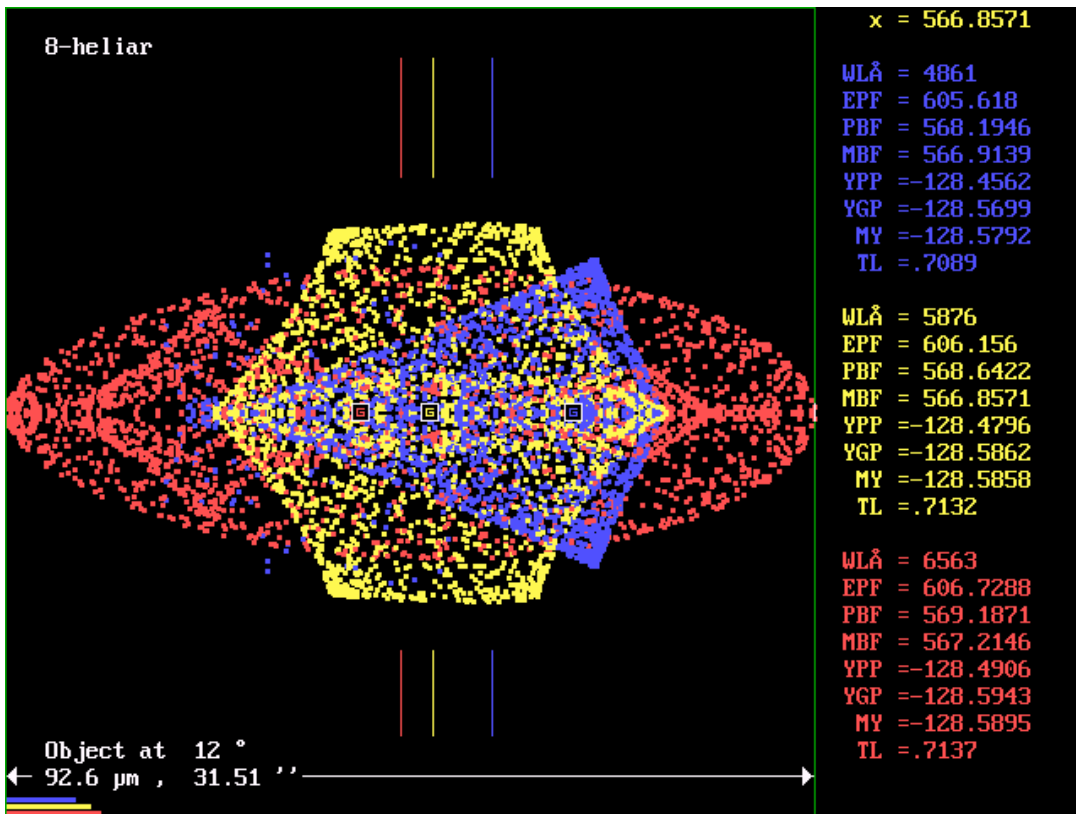

Fig 7 8-heliar with diaphragm 38 mm.

Principal planes

With the same optical system it can be shown that it is equivalent to a thin lens with regard to position of the paraxial image. The object and image distances are measured from the principal planes. These are defined by quantities (See Fig. 1)

$XOPP$ = distance from surface 1 to Object Principal Plane

$XIPP$ = distance from last surface to Image Principal Plane

The formula to apply in a thin lens is

$$(4) \quad \frac{1}{s'} - \frac{1}{s} = \frac{1}{f}$$

Where s' and s are the image and object distances, respectively, to the plane of the thin lens. In a complex system it is

$$s' = X_{image} - XIPP$$

$$s = X_{object} - XOPP$$

Let us consider an object at finite distance $X_{object} = -1500$ and zero height.

The distance $X_{image} = 942.1238$, that is PBF for the central color.

From the previous data in Fig 1 is taken

$$XIPP = -37.51381$$

$$XOPP = 89.94019$$

Therefore

$$s = -1500 - 89.94019 = -1589.94019$$

$$s' = 942.1238 + 37.51381 = 979.63761$$

The effective focal length f is $EPF = 606.1560$ for the central color and object at infinity.

These values comply exactly with eq. (4), and also for any other pair of conjugates.

The principal planes and pupils are illustrated in Fig. 8

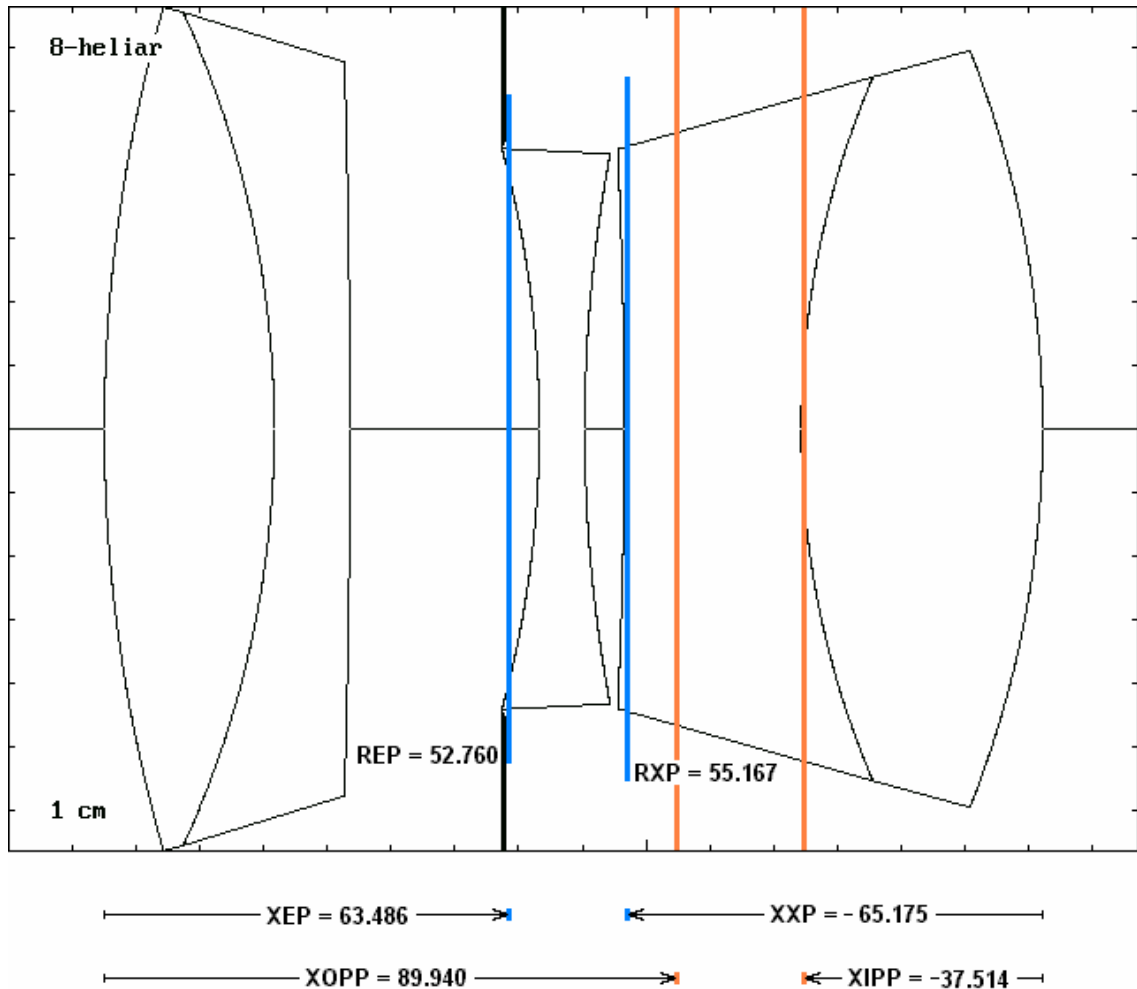

Fig. 8 Principal planes and pupils of 8-heliar

Primary and secondary spectrum

We take as an example the achromatic lens (from file: 4-acro).

We evaluate first the primary spectrum of the first component. To isolate it, we can define it with option **L**ens, or starting from 4-acro, redefining it as 2-lens

As the name begins with 2, surfaces 3 and 4 are eliminated. The resulting lens has a distance *MBF* of 526 mm in **F** color, 532 mm in **D** color, and 534.5 mm in **C** color.

The difference of distances in the extreme colors is the primary spectrum, and is 8.5 mm. The expression $\delta f / f = 1 / v$ (see text), gives 8.3 mm.

The full lens is not achromatized by making equal their red and blue *MBF*, but making equal the halos instead (Fig.9), that seems more convenient.

The secondary spectrum of the complete lens taking the average of the two *MBF*, is $\delta f_{sec} = 0.587$ mm, and the expression $\delta f_{sec} / f = (P2 - P1) / (v_2 - v_1)$ gives 0.6 mm.

The values of *v* and *P* are in the **G**lass option.

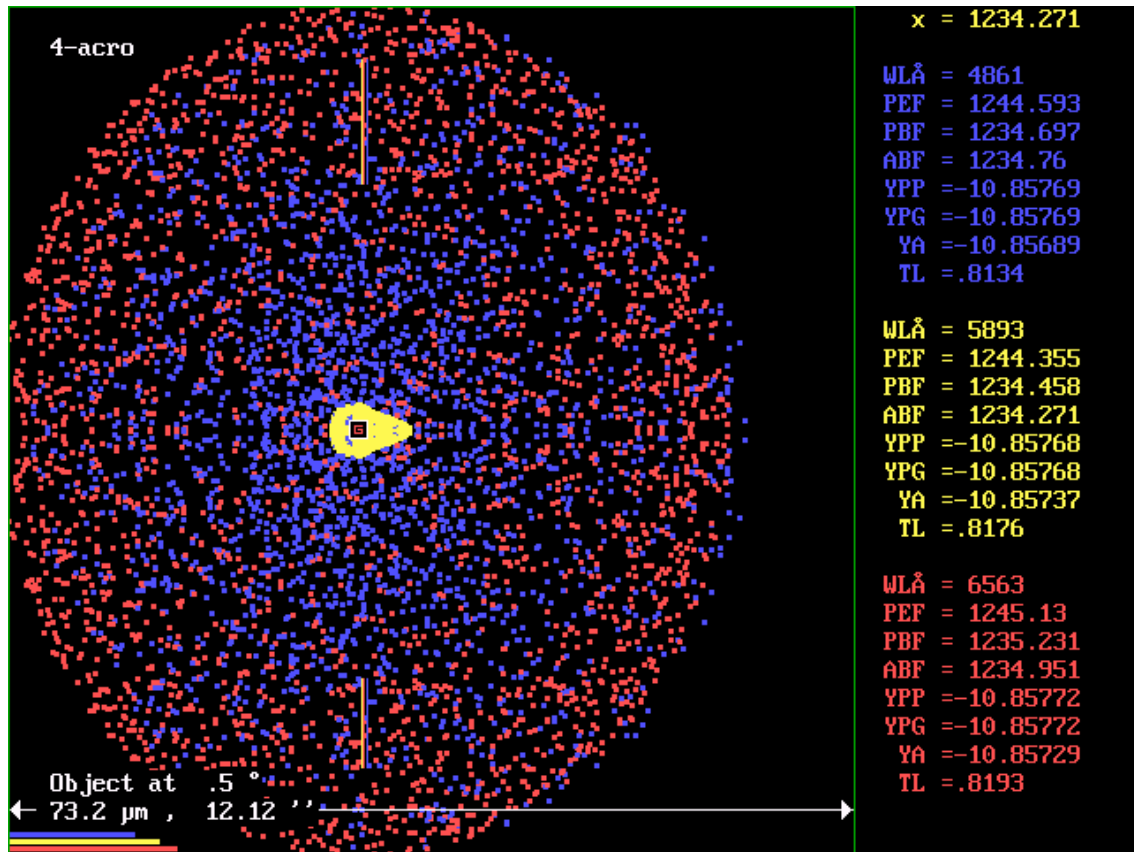

Fig. 9. Halos by secondary spectrum. D focus at center. Extra-axial image.

Changing the last radius to match the MBF blue and red, the resulting radius is $R_4 = -1891$ mm. In this case also is $\delta f_{sec} = 0.6$

Cemented aplanatic telescope doublet.

An achromatic lens only needs relations between the differences of curvature of each component. Hence there remain free two curvatures that may be used to cement the glasses and make flat the last surface.

The system 4-acro is aplanatic in addition to achromatic, this means that has neither spherical aberration nor coma. To achieve this it must be given values to all four radii of curvature separately. The resulting lens is called "Fraunhofer lens" and is designed with the program G-SUM.

The possibility of cementing it is of great practical value, because is simpler to make, more robust and insensitive to maladjustments because it is a single piece, and no needs antireflection layers at the inner surfaces. It is possible to reach an aplanatic cemented design with the same pair of common glasses, paying the price of aspherizing the last surface. But as the aspherizing depth is small, the system retains its practical value. As the chromatic aberration is dominant, it is illustrative to see the image in central monochromatic light to appreciate the geometrical aberration in both systems. It seems that the chromatic correction is somewhat improved too.

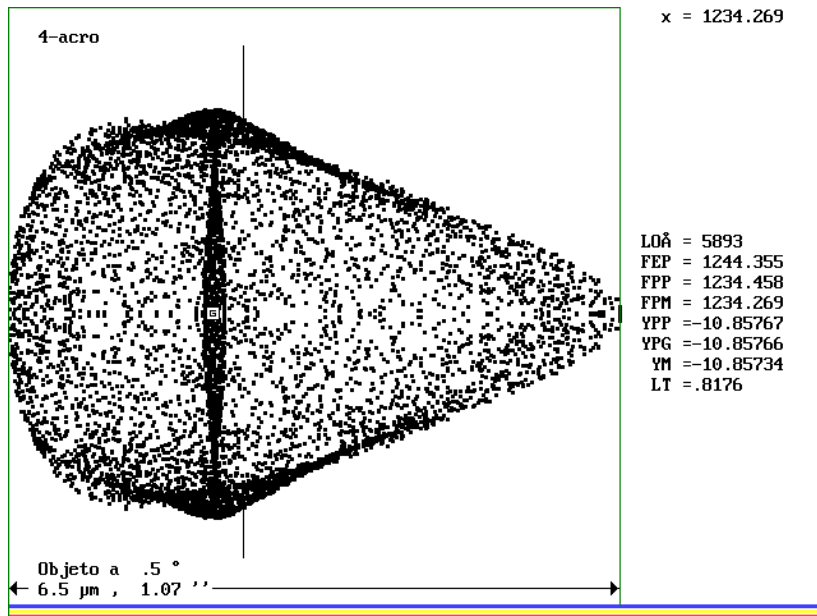

Fig 10. Extra-axial monochromatic image of 4-acro

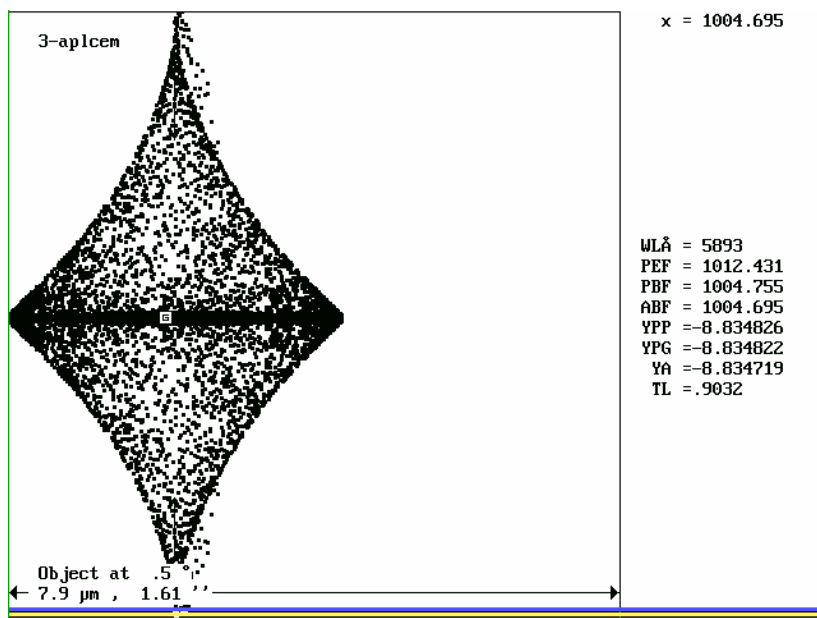

Fig 11. Extra-axial monochromatic image of 3-aplcem

S	Curv. Radius	Clr.Radius	Drk.	Distance	Glass	a,d
1	628.047	50.000	0.00	10.000	1 BK7	d
2	-359.725	50.000	0.00	6.500	F2	
3	-1366.530	50.000	0.00	0.000	1	a
Aspherics						
S	Citric const.	Aspheric (4)	Aspheric (6)	Aspheric (8)		
3	0.000	-1.31999E-10	0.00000E+00	0.00000E+00		

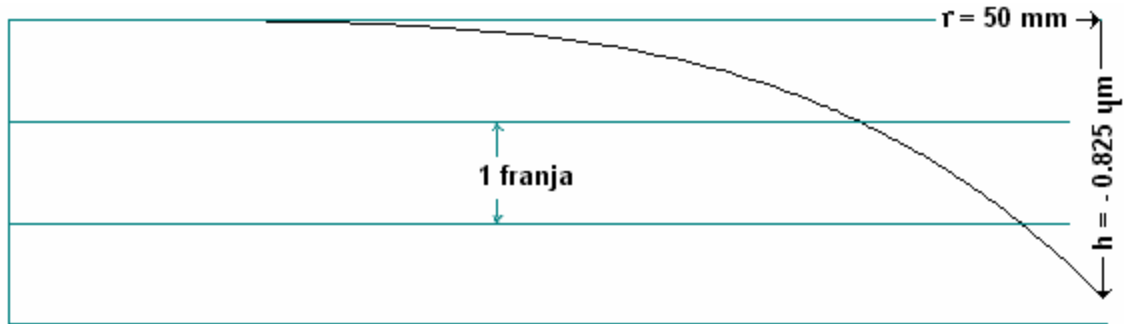

Fig 12. Aspherization in surface 3

The aspherization is a low border reaching a depth less than 1 micron. Contrasting over a test plate of that curvature it is 2.8 fringes of sodium light, some easy to achieve.

Aplanatic point of a sphere.

In a sphere of index n and radius R there exists an interior point whose image is virtual and free from spherical aberration and coma. The axial image is pointlike, and even an extreme ray normal to the axis pass through that point.

Taking a diameter of the sphere as axis, if the object is placed at a distance

(5) $\frac{R}{n}$ from the center

The virtual image is formed at a distance

(6) nR from the center

This is the definition of aplanatic conjugate points.

The consequences follow from Fig. 10.

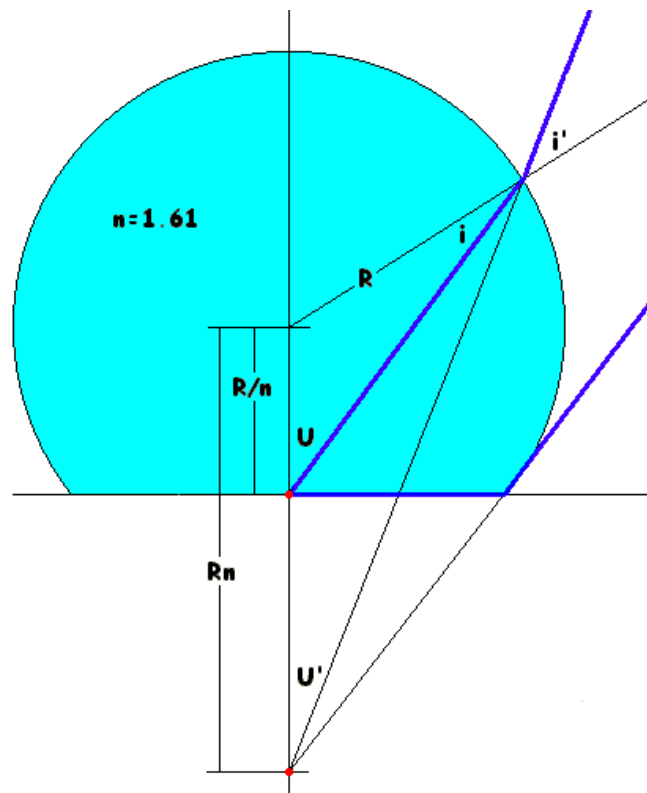

Fig 10. Aplanatic conjugates in a sphere

$$\frac{R}{n \operatorname{sen} i} = \frac{R}{\operatorname{sen} U}$$

$$\frac{R n}{\operatorname{sen} i'} = \frac{R}{\operatorname{sen} U'}$$

$$n \operatorname{sen} i = \operatorname{sen} i'$$

From this follows

$$i' = U$$

$$i = U'$$

Also

$$n \operatorname{sen} U' = \operatorname{sen} U$$

Limiting case

$$U = 90^\circ \quad (\text{Normal to the axis})$$

$$i' = 90^\circ \quad (\text{Tangent to the sphere})$$

In order to be possible to place an object, the sphere is limited by a plane, that is the first surface of a lens, and in the limiting case the ray emerges from the object in that plane.

This lens is hyper-hemispherical. Its thickness d_1 is the distance between the object and the second surface, of radius now called R_2 , and is

$$d_1 = \left(1 + \frac{1}{n}\right) R_2$$

System of consecutive aplanatic lenses.

Considering the virtual image as object it may be produced an aplanatic refraction with a second lens. The first surface of this lens is concentric with the virtual image of the former, so that there is no refraction in it.

As its radius of curvature will be greater than R_2 , they may be put in contact.

Then

$$(7) \quad R_3 = R_2 (1 + n)$$

The second surface is determined as in the former case,

$$(8) \quad R_4 = \frac{R_3 + D}{1 + \frac{1}{n}}$$

R_4 is the radius of a solid sphere that would have as object the virtual image complying conditions (5) y (6)

D is a convenient constant thickness, set for constructive reasons.

Eqs. (7) y (8) are recursive and can be made a series of lenses that will decrease the initial divergence of the bundle, but never allowing it to be parallel.

This configuration is used mainly in high power microscope objectives.

The resolving power of a microscope depends on the angle of entrance to the first lens of the objective because the object behaves as a diffraction grating where the fine details diffract at large angles. The Abbe theory of the microscope is based upon this consideration.

With several aplanatic lenses the initial bundle is carried to a divergence manageable by the rest of the system, that will take the charge of producing a real and corrected image.

Example: From file: 6-aplana

This system has 3 consecutive aplanatic lenses. The order of dimensions belongs to a high power microscope objective. Applying Eqs. (7) and (8) follow the radius

$$R_3 = -2.035917, \quad R_4 = -1.595201, \quad R_5 = -4.163714, \quad R_6 = -2.907797$$

In order to the calculation does not shows aberration in addition to numerical errors, the radius must be given to this precision, over fictitious in practice.

In the same way all other parameters (*dio* = object distance)

$$n = 1.61015, \quad D = 0.55 \quad dio = -0.484427$$

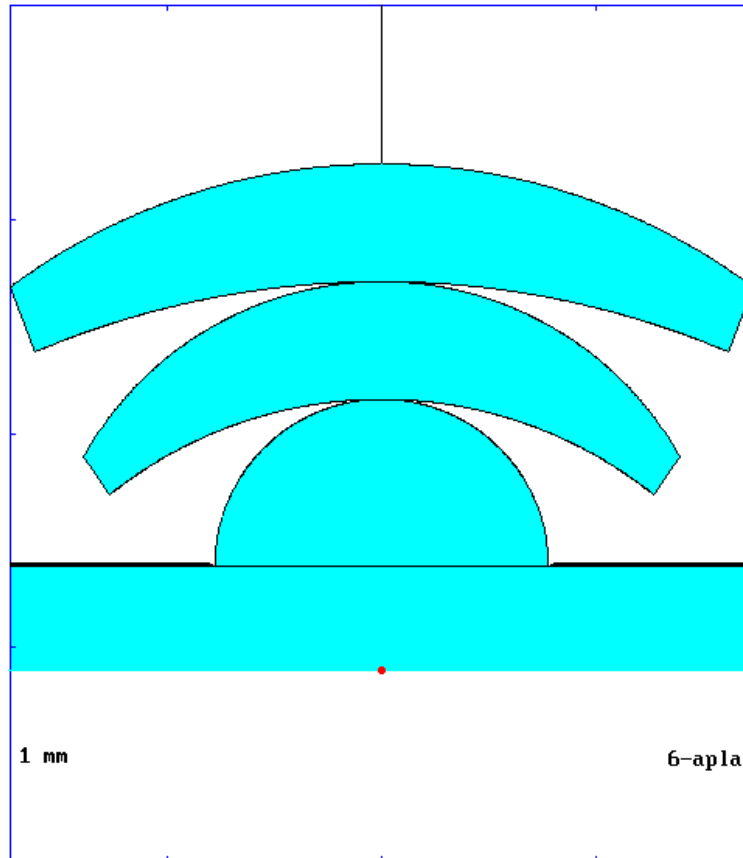

Fig 11. 6-aplana. Exact drawing.

The program cannot deal with an hyper-hemispherical surface, and it was taken the object in immersion in a medium with the same index as the lens. The aperture diaphragm was taken as the front plane surface of the hemispherical lens, and the rays coming from the hyper-hemispherical part does not enter the system.

The complete prescription showing only 3 decimals is

S	Radius Curv.	Clr. Radius	Drk.	Distance	Glass	a,d
1	0.000	0.780	0.00	0.780	SK1	
2	-0.780	0.780	0.00	0.000	1	d
3	-2.036	1.273	0.00	0.550	SK1	
4	-1.595	1.396	0.00	0.000	1	
5	-4.164	1.622	0.00	0.550	SK1	
6	-2.908	1.736	0.00	0.000	1	

In Fig. 12 the image is only evaluated in 5893 Å, that corresponds with the index used. The chromatic aberration is much larger than the geometrical for small departures from the axis.

The axial image only show the numerical errors and is not of interest.

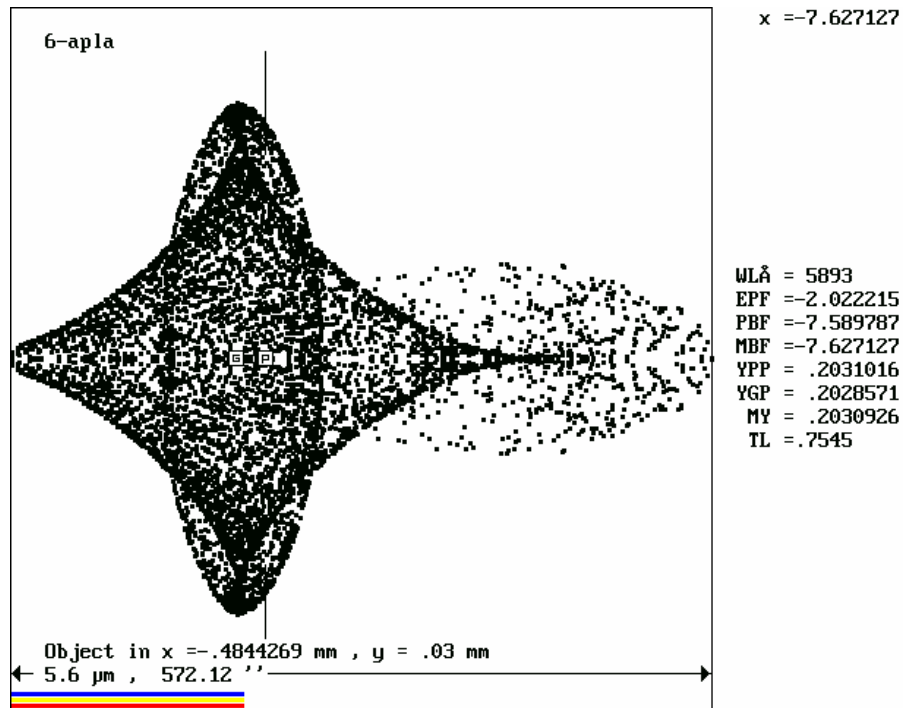

Fig 12. Extra-axial image at 0.03 mm from axis

Achromatization by ghost surface

If a pair of glasses adequate to produce achromatization has a wavelength at which their indices coincide, that is, their dispersion curves cross, at that wavelength there is only one glass and the surface will appear subtly as the color change. It can be taken the matching color as the design one for correction of geometrical aberrations and the chromatism be left to the ghost surface. This can have any curvature and does not affect the geometric correction, but yes the chromatic one.

Pairs of glasses with crossing dispersion curves are not common. To search for them in the catalogs it was written the program SPAIR (Search for Pairs) An example of output of this program is in Fig. 13. It is detected the crossing of the curves, that may be displayed for more details. The red part of the curves are extrapolated values outside the limits set by the Scott catalog for his interpolation formula and may be in error

The more the Abbe numbers differ, the better the pair performs.

Some examples of pairs are

SK14 - F5, SK16 - F9, SSK2 - F13, SK7 - BAF5, SK5 - LF2

The crossing points are very near the D line, that is an advantage for visual systems

The best pair of these is SK16 - F9 with a v difference of 22.2

This method seems ideal to be applied in the chromatic correction of aplanatic menisci.

The geometrical correction is very good in them but the chromatism is enormous if they are made of one glass. Any other surface perturbs the aplanaticity in the design color.

Then the ghost surface proceed to herd the colors.

The program SPAIR must be together with ASOP to use the same glass file.

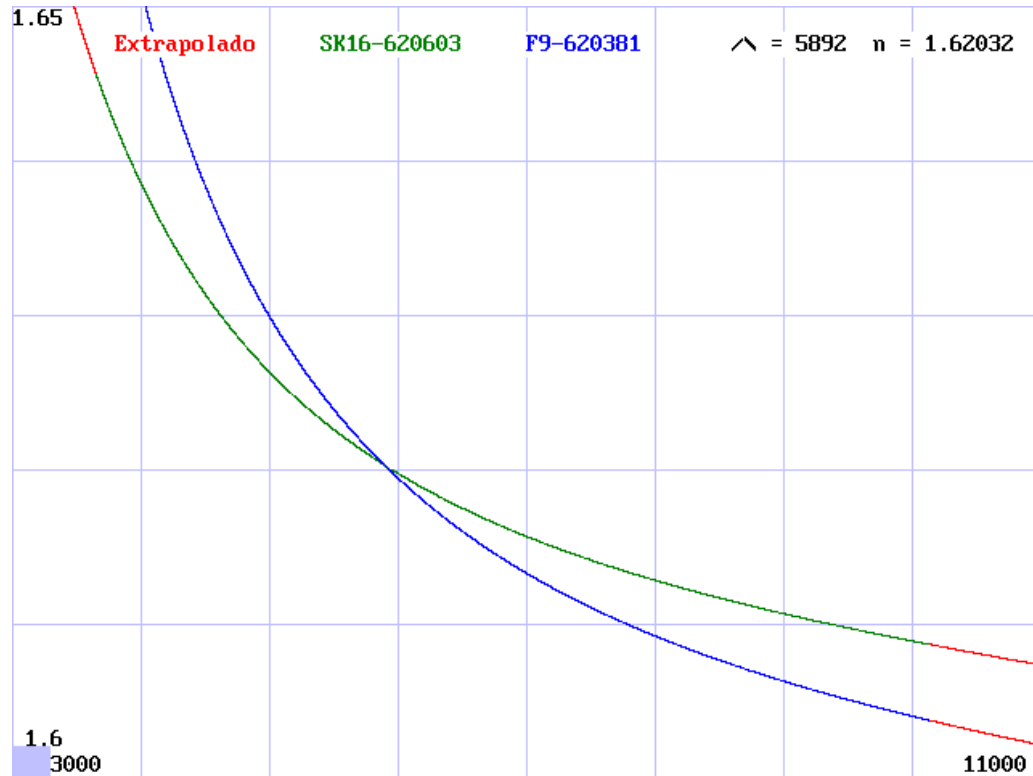

Fig 13. Search for coincidences

Using the said pair it was designed an aplanatic meniscus and it was tried to achromatize it. The λ of coincidence is 5892 Å.

Complying with the aplanaticity conditions seen before, it was optimized by hand respect to the curvature of the surfaces, their thickness and sequence of glass.

(System 3-aplacr).

The result is fortunate because the ghost surface is plane or as near that it can be left so. (Fig. 14). The order of the glasses is first F9, and the thicknesses must have a constant sum.

The prescription is (showing three decimals).

S	Radius Curv.	Clr. Radius	Drk.	Distance	Glass	a, d
1	-1.500	1.000	0.00	0.260	F9	d
2	0.000	1.000	0.00	0.440	SK16	
3	-1.360	1.000	0.00	0.000	1	

The extension of the polychromatic axial image is 1.3μ .

Swapping the glasses is 46.5μ

With SK16 only is 17.3μ

With F9 only is 27.9μ

The image in central color is, of course, pointlike within numerical errors.

The geometrical aberrations (only astigmatism) and chromatic are of the same magnitude at a distance of 0.07 mm from axis. (Fig. 15).

It is nearly diffraction limited up to 0.1 mm .

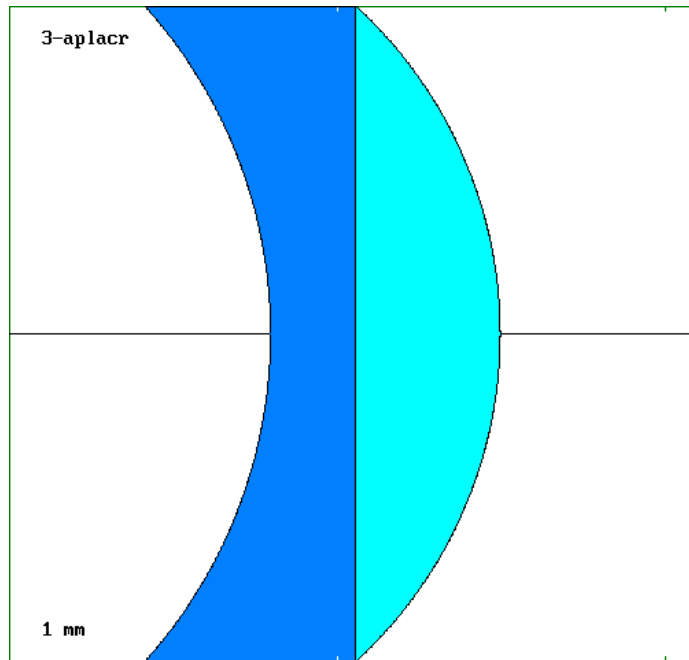

Fig. 14 Aplanatic system achromatized by a ghost surface

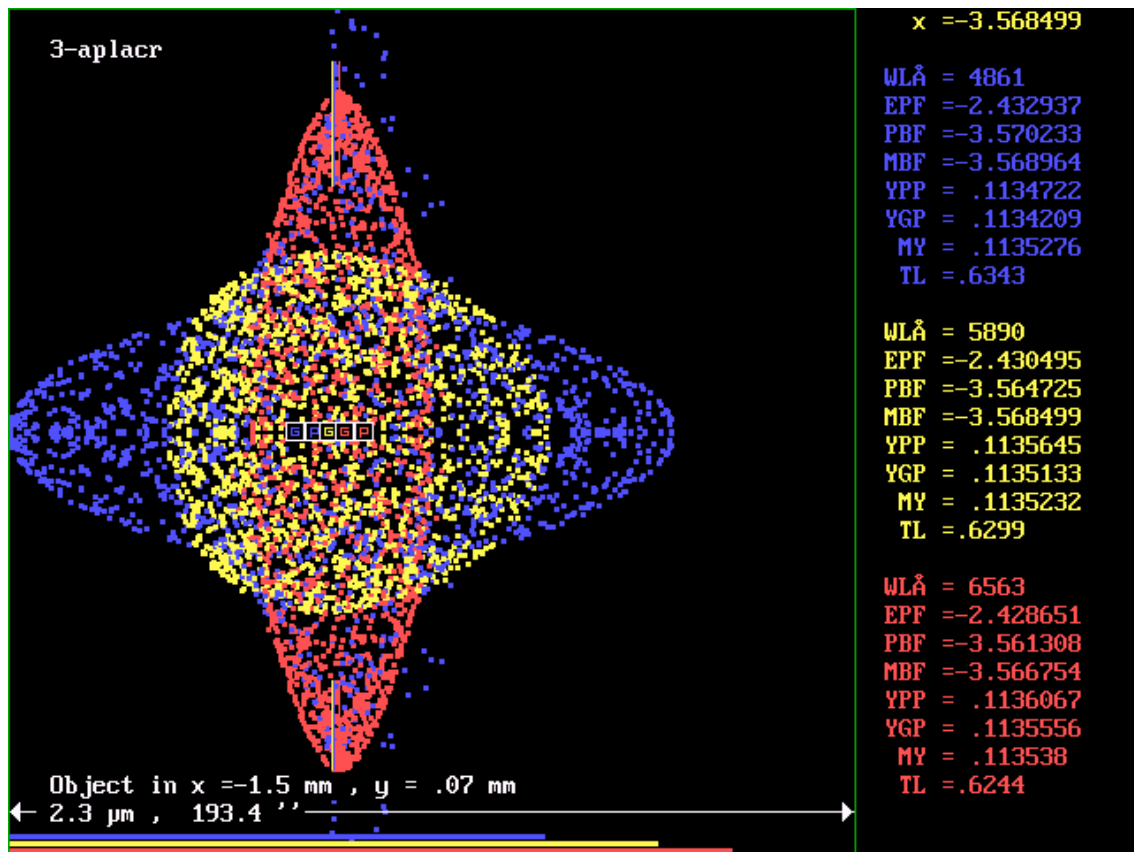

Fig. 15. Polychromatic extra axial image

Achromatic Bowers system

The concentric Bowers system (4-bowers) is very promising to achieve a large field free from geometric aberrations and was designed for the blue end of the spectrum due to its photographic application, but the chromatism is so large that that it becomes useless.

The use of a ghost surface may improve the situation because the concentricity is maintained for the central color, but now to use the pair of glasses SK16 – F9 the central λ must be 5892 Å. and the usual spectral range F-D-C

The system 5-bowac has one more surface, that number 3 that brings the F9, but to adjust parameters of monochromatic correction this surface does not exist

The method is to vary R_2 and R_4 in color D maintaining the concentricity.

Having done this it is varied R_3 to minimize the chromatism.

Swapping the glasses it may be reached something similar with another value of R_3 .

For zero field the monochromatic and polychromatic images are equal and near the diffraction limit but the extra-axial images suffer from lateral chromatism.

S	Curv. Radius	Clr. Radius	Drk.	Distance	Glass	a, d
1	0.000	200.000	0.00	713.000	1	d
2	-713.000	235.000	0.00	30.000	SK16	
3	-794.600	235.000	0.00	30.700	F9	
4	-773.700	235.000	0.00	1692.300	1	
5	-2466.000	310.000	0.00	0.000	-1	

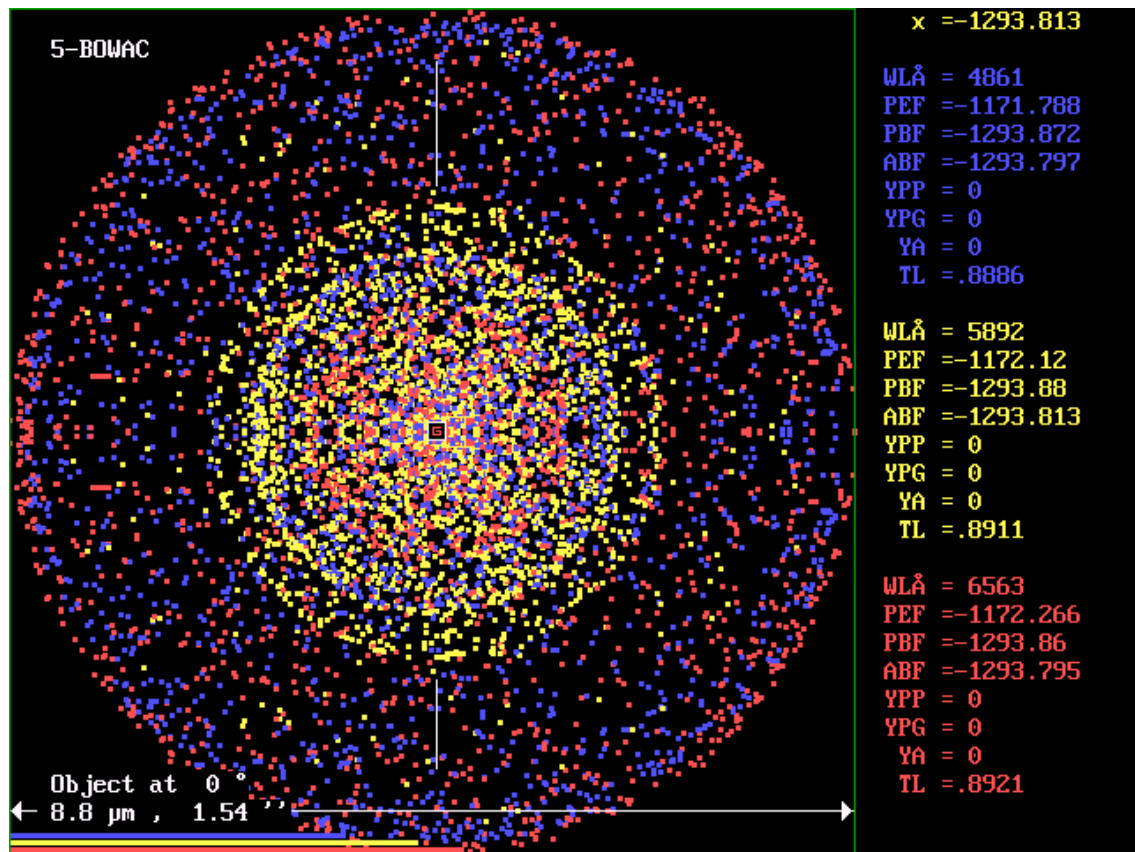

Fig. 19. 5-bowac. Axial image

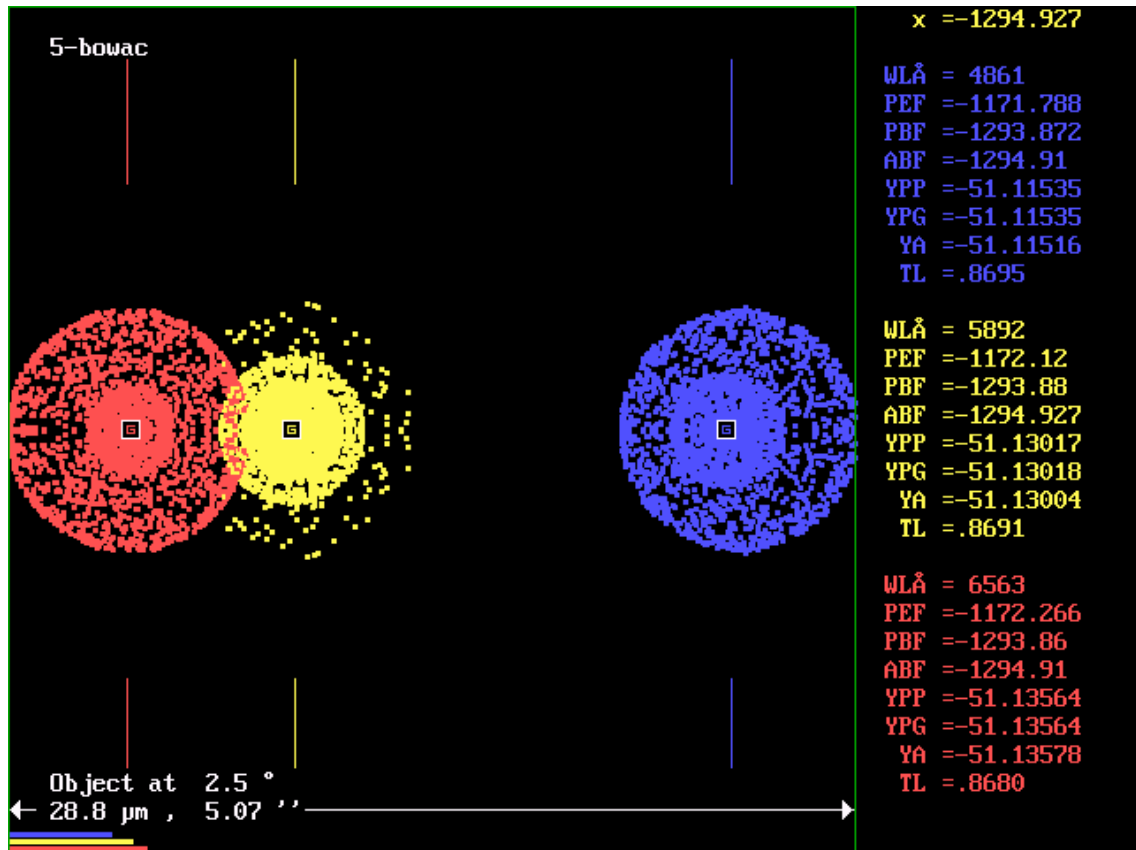

Fig 20. 5-bowac. Image at 2.5 degrees

The achromatization can be appreciated putting both components of the same glass, the monochromatic images are still corrected but they are very separated axially.

This type of systems can be carried to large fields and apertures by introducing additional correctors.

Massive use of aspherics.

We shall see now how can be used aspherics of higher order to correct the optical system of a large telescope. This telescope is not built yet, but may be a candidate for a next generation telescope. There is much literature about this and the design was kindly furnished by Dr. Jingqan Cheng (Ref. 2), one of the contributors to the project, during a visit to Argentina.

The generic name is Mersenne-Schmidt telescope. The following is its prescription. (System 3-Mersch)

S	Curv. Radius	Clr.Radius	Drk.	Distance	Glass	a,d
					1	
1	-16000.000	2500.000	1600.00	-3826.056	-1	ad
2	-8135.749	1468.000	0.00	7826.260	1	a
3	-8000.000	2236.000	0.00	0.000	-1	a

Aspherics

S	Citric const.	Aspheric (4)	Aspheric (6)	Aspheric (8)
1	-1.000	0.000000E+00	-6.71398E-23	-1.67188E-30
2	0.000	-6.43105E-14	-1.35043E-20	-6.68874E-28
3	0.000	-5.03860E-15	-4.23422E-22	6.67396E-32

It is a system of three mirrors, the primary has 5 meters of diameter and highlights a large central obstruction to accept a large field. By a complex system of high order aspherics it is possible to keep a highly corrected image up to 2.5 degrees of semifield, a performance similar to a Schmidt camera, but only with mirrors. The only drawback may be the degradation of the diffraction image by the central obstruction.

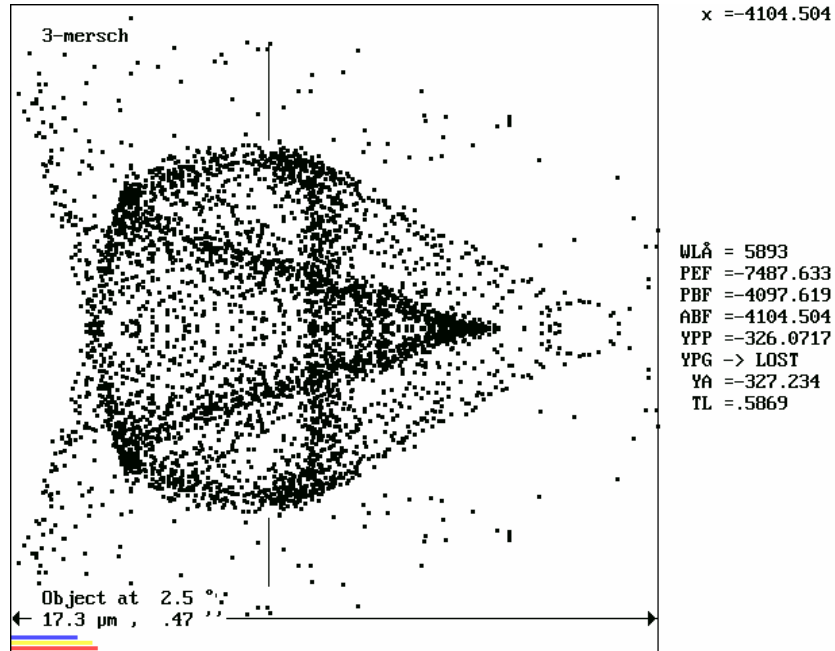

Fig 21

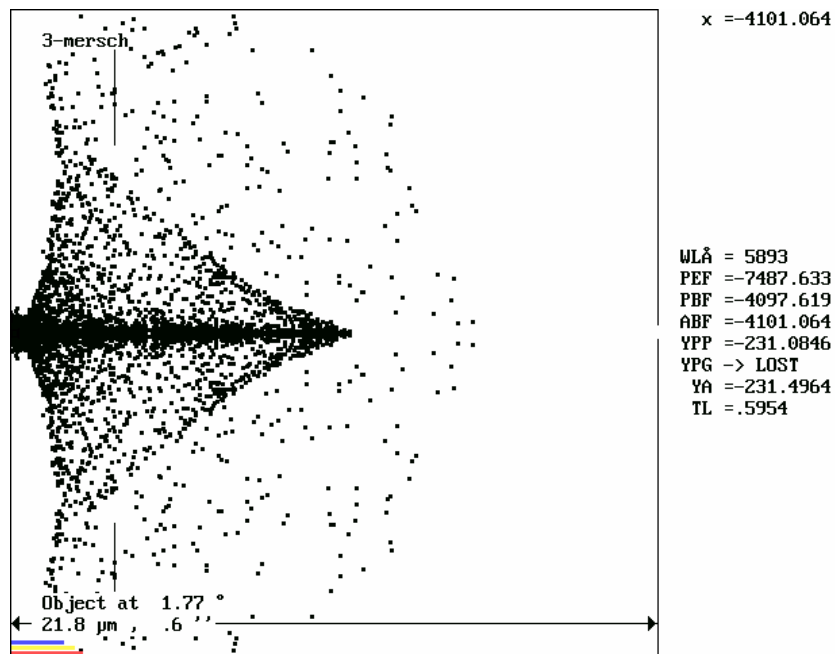

Fig. 22

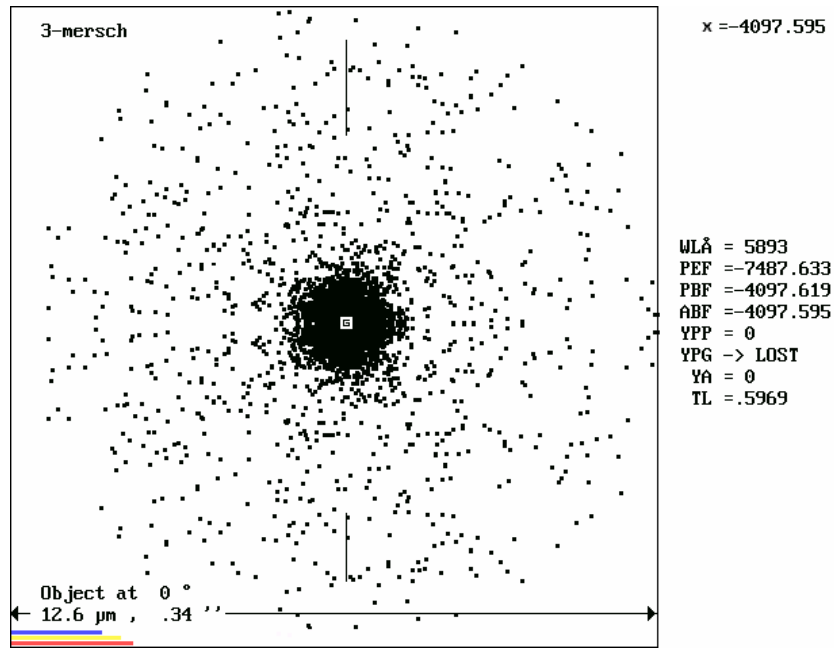

Fig. 23

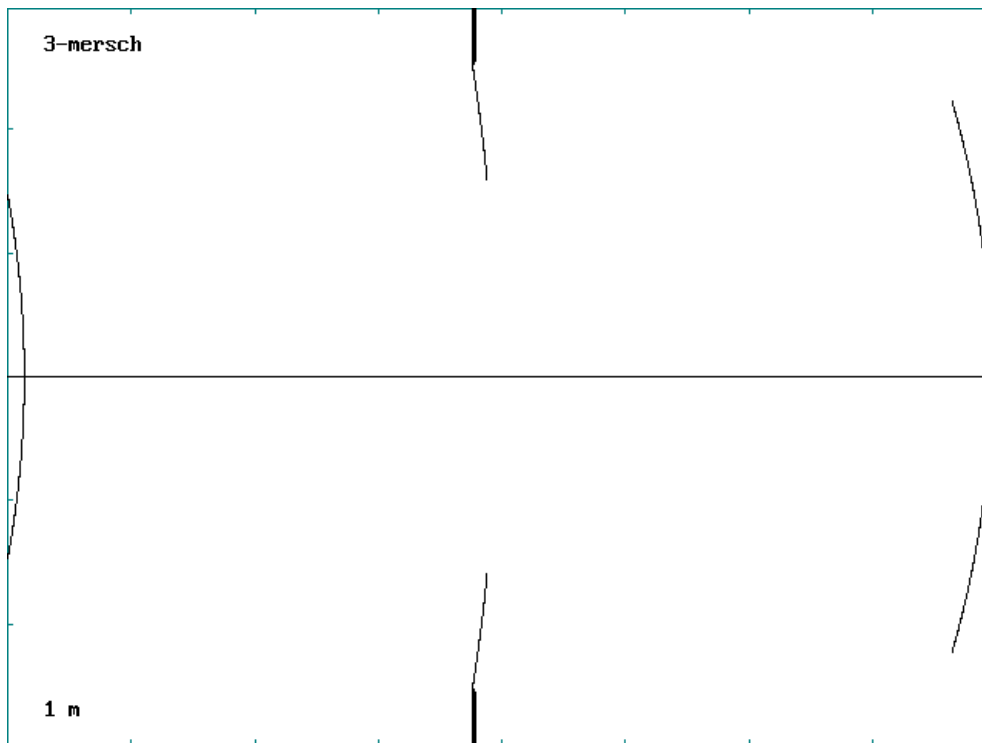

Fig. 24. Profile of 3-mersch

Something more accessible

The former examples deal with simulated optical systems. For a better idea of how simulation reproduces reality, we will see a simple system that permits to verify experimentally the results without appeal to special instruments. It is a loupe bought at a toy store (; It is also chinese !)



Fig 25. The lens and the elements needed to define it by the prescription below. Lacking a refractometer it was assumed the glass is BK7 (System 2-lupach)

In Fig. 26 it is seen the experimental setup, very simple indeed. The point source of white light is realized by a steel ball illuminated by a flashlight.

S	Curv. Radius	Clr. Radius	Drk.	Distance	Glass	a, d
1	270.800	50.000	0.00	12.000	1 BK7	d
2	-270.800	50.000	0.00	0.000	1	



Fig 26. Experimental setup.

In Fig 27 they are in addition to the diagram the coordinates of object and image and the dimension of the image.

The image, ≈ 8 mm long is large enough as to be photographed without microscope and appreciate its geometrical and chromatic details. By the same reason diffraction is negligible and the ray model is well valid. Compare with the former example.

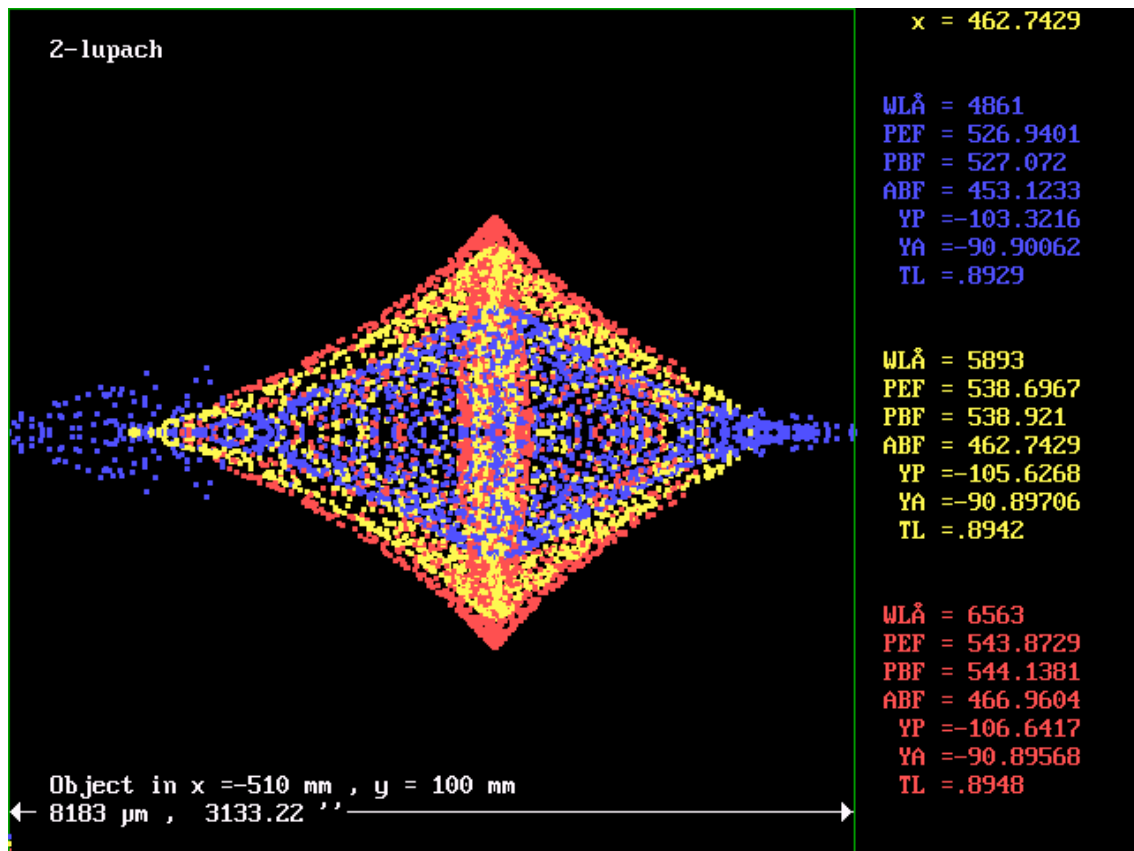

Fig. 27. Simulated image.

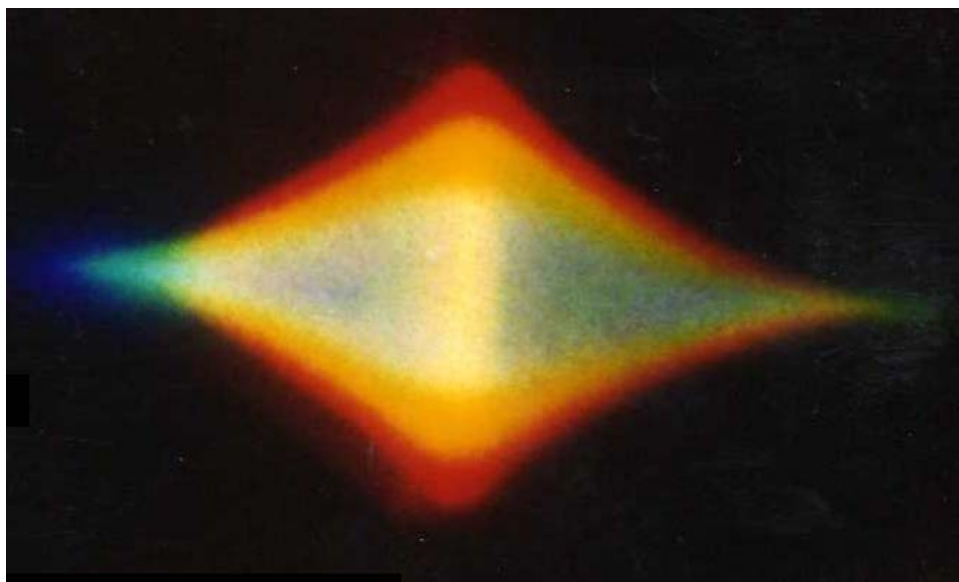

Fig. 28. Real image

It can be discerned the upper and lower red and yellow fringes. The central yellow column with weak red borders The weak blue cloud at the left side and a hint of blue at the right side. The slightly darker right side of the bluish central image

All these details were obtained with the crude equipment shown.

A better approximation would be to use a precision optical bench and a program to include diffraction effects.

Additional utilities of the program

Once entered the system (8-heliar in this case) and selected the λ in which to be evaluated, it proceeds to image evaluation selecting **O**bject in the options bar.

With option **G**lass it is obtained the following:

Values in:		4861	5876	6563	\AA
Glass	Abbe number	Partial dispersion			
SK51	60.28	.69611			
SK11	60.76	.69504			
LF2	40.92	.70416			
SK11	60.76	.69504			
SK51	60.28	.69611			

Also, with options **F**, **D**, **C** it can be replaced in the glass column the indices in that λ .

Object Glass Index: F D C Explicit						
S	Radius curv.	Radius clr. drk.	Distance	Glass	a, d	
				1		
1	240.354	66.3	0.0	26.67	1.61777	
2	-156.981	65.4	0.0	11.88	1.56101	
3	-1913.832	57.7	0.0	29.71	1	
4	-168.375	44.3	0.0	7.14	1.58495	d
5	236.282	43.3	0.0	6.21	1	
6	-919.823	43.8	0.0	27.75	1.56101	
7	141.292	55.4	0.0	37.90	1.61777	
8	-160.249	59.3	0.0	0.00	1	

With the option **E**xplicit it may be set an explicit arbitrary index to each glass, not originated by the interpolation formula.

If it is studied a glass, (BK7 in this case) besides the index in any λ there can be seen other data from the catalog.

BK7-517642

preferido

Dilatation coefficient, (-30°C - 70°C) in 10 ⁶ /°C	_____	= 7.1
Dilatation coefficient, (20°C - 300°C) in 10 ⁶ /°C	_____	= 8.3
Distension temperature in °C	_____	= 559
Softening temperature in °C	_____	= 719
Isobaric specific heat in J/g°C	_____	= .858
Thermal conductivity in W/m°C	_____	= 1.114
Density in g/cm ³	_____	= 2.51
Young modulus in 10 ⁻³ N/mm ²	_____	= 81
Poisson ratio	_____	= .208
Knoop hardness	_____	= 520
Class of bubble content (0 - 3)	_____	= 0
Class of weather resistance (1 - 4)	_____	= 2
Class of stain resistance (0 - 5)	_____	= 0
Class of acid resistance (1 - 4 or 51 - 53)	_____	= 1
Class of alkali resistance (1 - 4)	_____	= 2
Internal transmittance at 4000 Å over 5 mm	_____	= .998
Internal transmittance at 4000 Å over 25 mm	_____	= .991
Estimated price related to BK7	_____	= 1

BK7-517642

Coefficients of Schott dispersion formula

A 0 =	2.271893
A 1 =	-1.010808E-02
A 2 =	1.059251E-02
A 3 =	2.081696E-04
A 4 =	-7.647253E-06
A 5 =	4.924099E-07

Once evaluated the image appears a similar options bar, where in place of the indices are the focus **F**, **D**, **C**. And with the option **E**xplicit it may be set an explicit arbitrary plane to show the image, not originated by the formula for least dispersion RMS. This was used in the example of Casleo telescope.

References.

- 1 – Lens design for a 609.6 mm, f / 6, 30° field objective. Berlyn Brixner. Applied Optics, Vol. 5, N 12, December 1966, Pag. 1948.
- 2 – Jingqan Cheng and Ming Liang. SPIE Proccedings. February 1990.